

# 6261 Dover Road

Nanaimo, BC

**1536**  
FINISHED SQFT

**152**  
UNFINISHED SQFT

**516**  
GARAGE SQFT

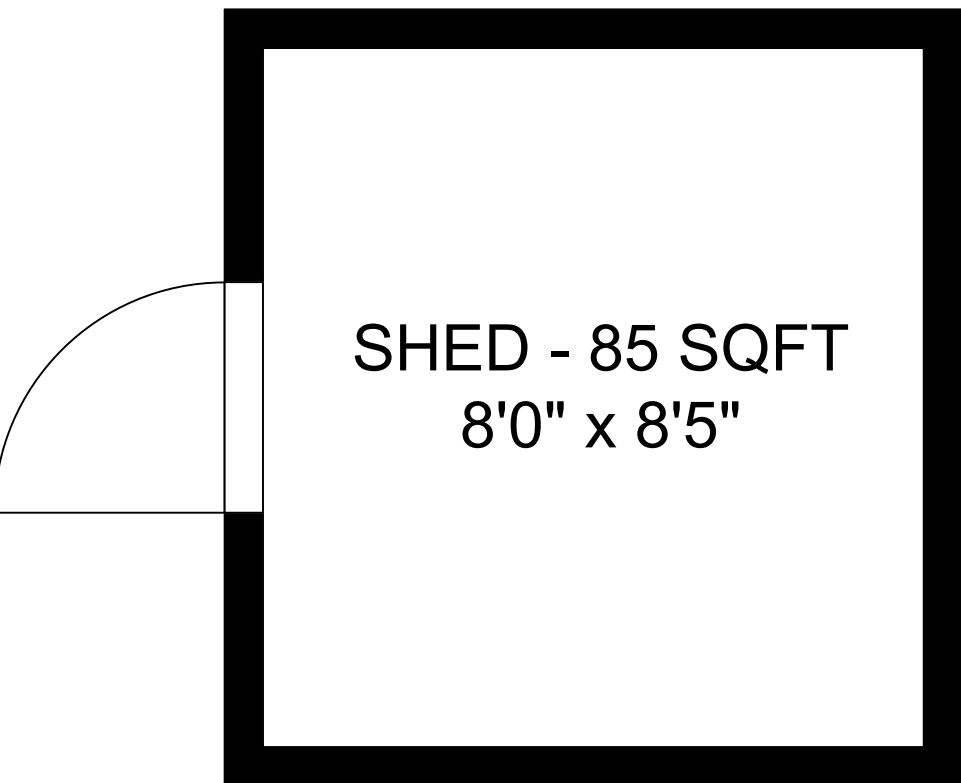

MAIN LEVEL - 1536 SQFT  
UNFINISHED - 152 SQFT  
CEILING HEIGHT - 8'0"

